

# African VLBI

Nkululeko Qwabe  
South African Radio Astronomy Observatory  
DARA  
11 June 2021

[www.sarao.ac.za](http://www.sarao.ac.za)

The South African Radio Astronomy Observatory (SARAO) is a National Facility managed by the National Research Foundation and incorporates all national radio astronomy telescopes and programmes.

# Overview

- African VLBI Network
- GRAO
- VLBI
- VLBI Operations
- MeerKAT-VLBI

- Network of VLBI capable telescopes in SKA partner countries
  - Ghana
  - Kenya
  - Zambia
  - Namibia
  - Mozambique
  - Madagascar
  - Botswana
  - Mauritius



# AVN

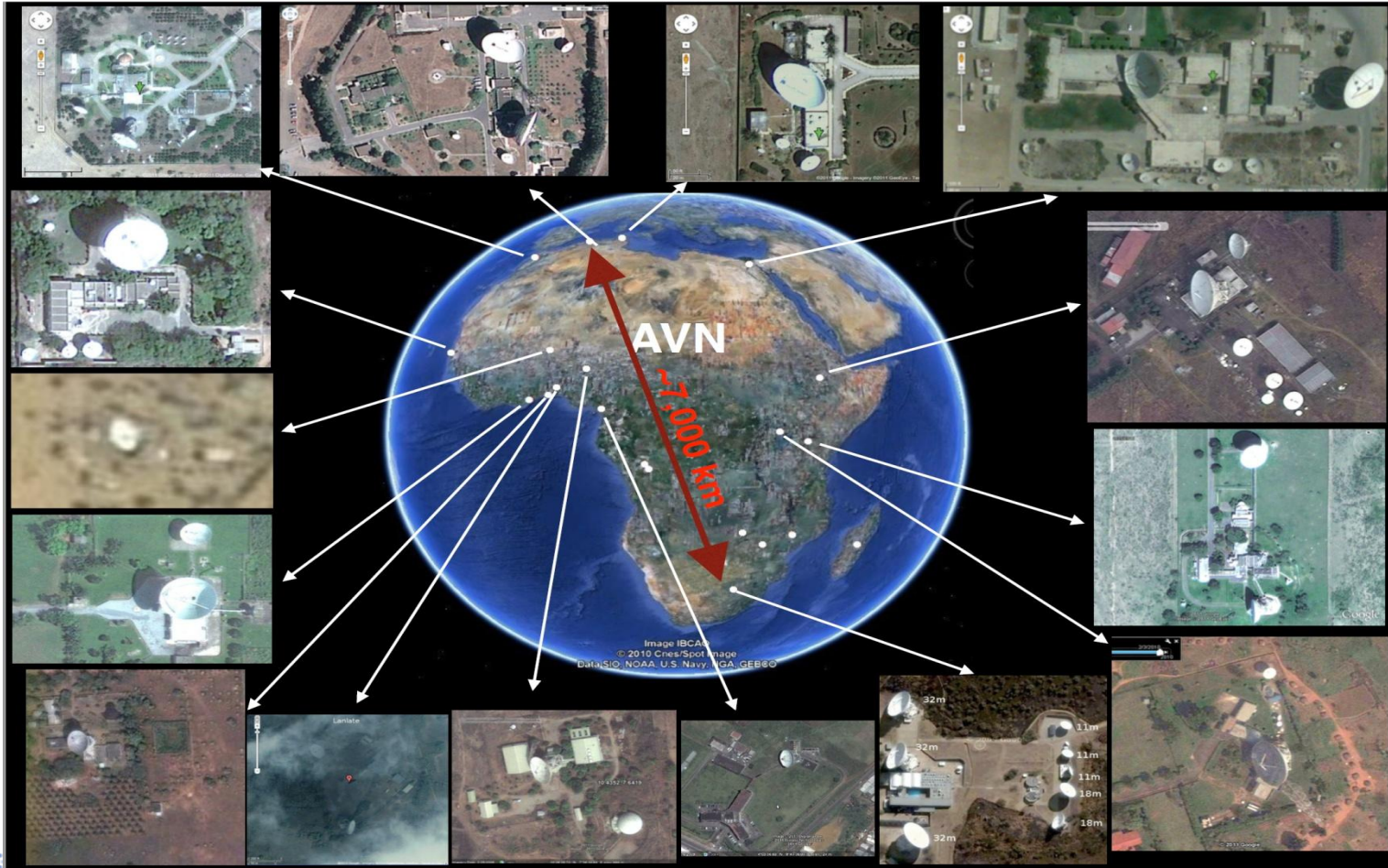

# AVN

## Conversions

Ghana Kutunse (GRAO)



Kenya Longonot



Zambia Mwembeshi



Madagascar Arivonimamo



# AVN

- Develop human capital for the SKA era
  - Skills and knowledge transfer (DARA, training)
- Regulations and institutional capacity
- Build, maintain and operate
- Engineering and science disciplines:
  - Structural and Mechanical Engineering
  - RF Engineering
  - Analog and Digital Electronics
  - Electrical and Power
  - Civil
  - Software
  - Science (Mathematics, Computer Sciences, Data Sciences, Astro-Physics, etc...)
- Administration (HR, Finance, Procurement, Reception, etc...)

# AVN

- HPC Data Centers
- Instrument Collocation programme (GRAO is piloting)
- Two Antenna Interferometers
- COVID19
  - Diversion of funds
  - Short-term strategy has changed to smaller steps
  - Capacity building
- Long-term strategy remains unchanged – funding uncertain

# VLBI

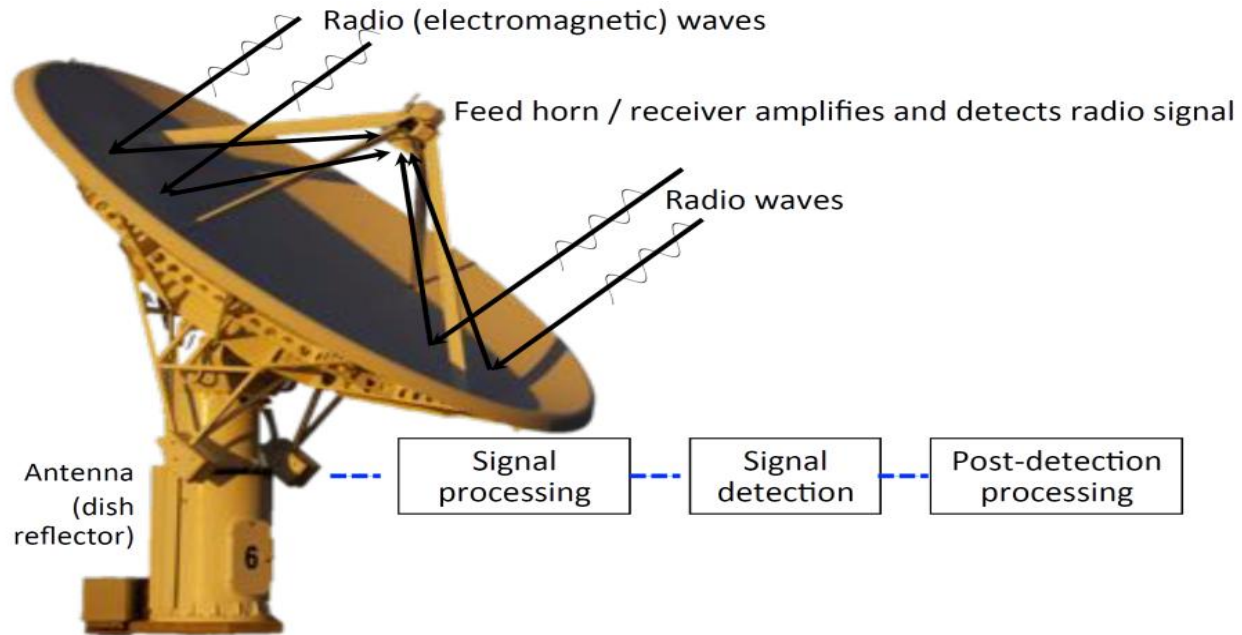

# VLBI

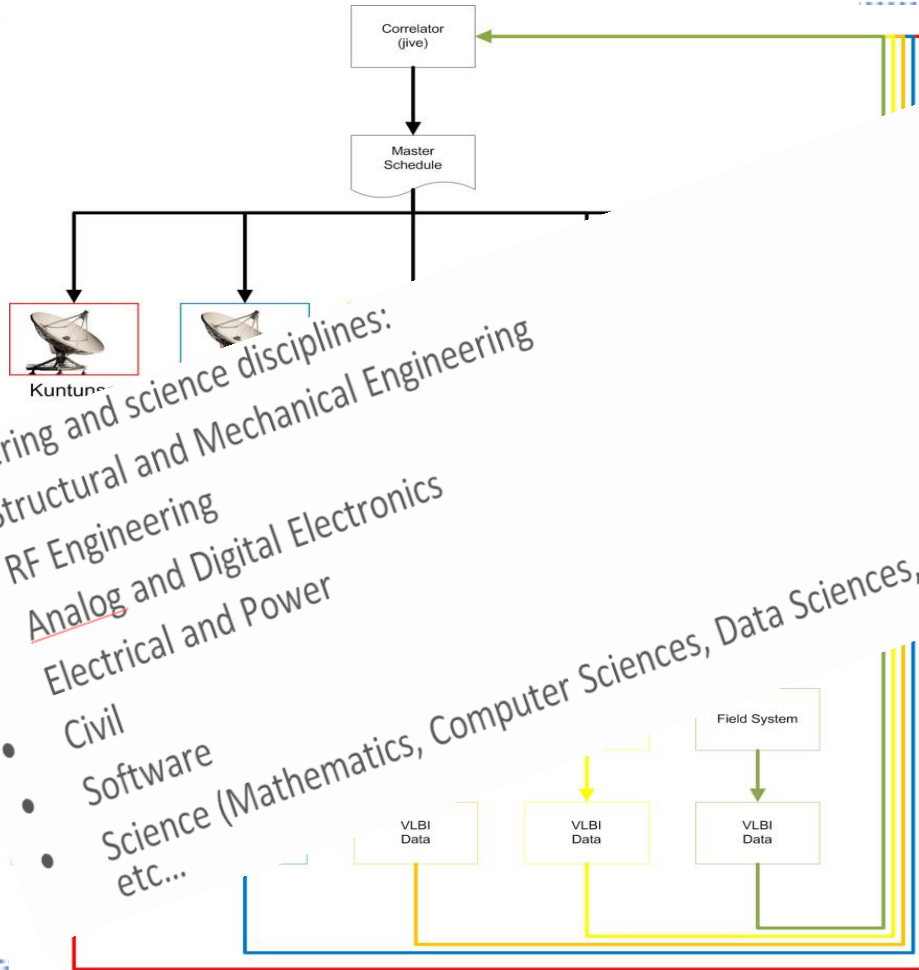

# VLBI Station

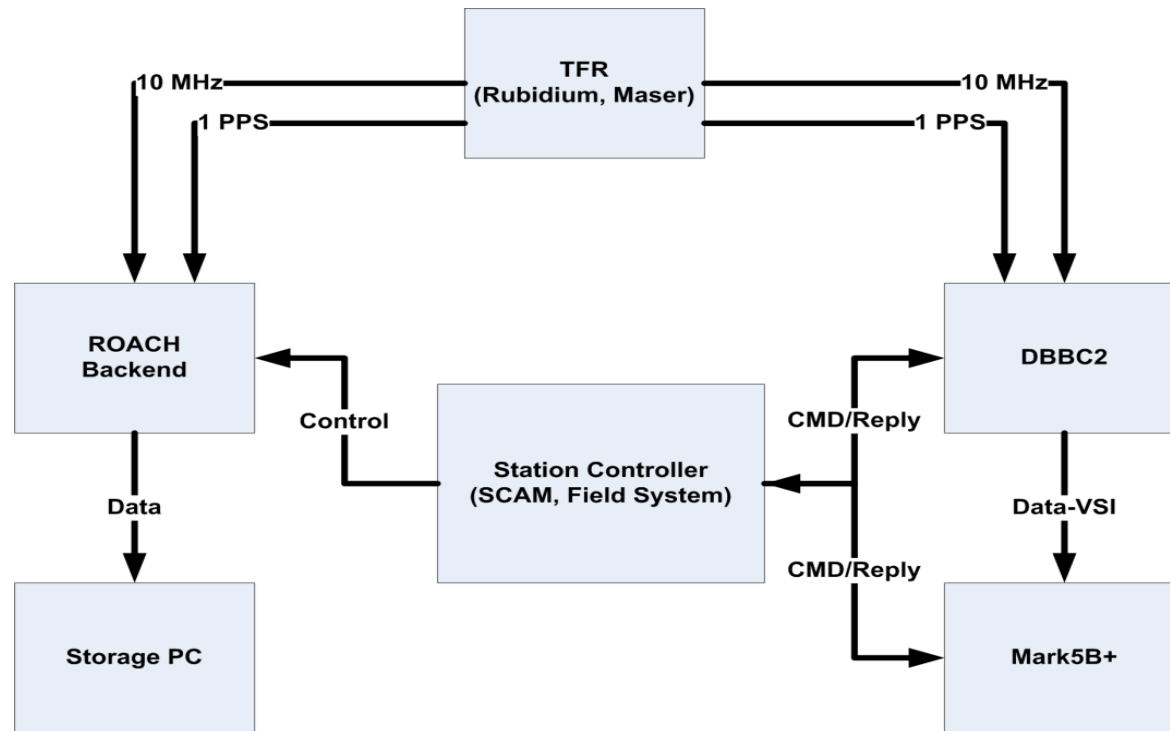

# VLBI Station

## The Allan Variance – A graphical look at clock performance

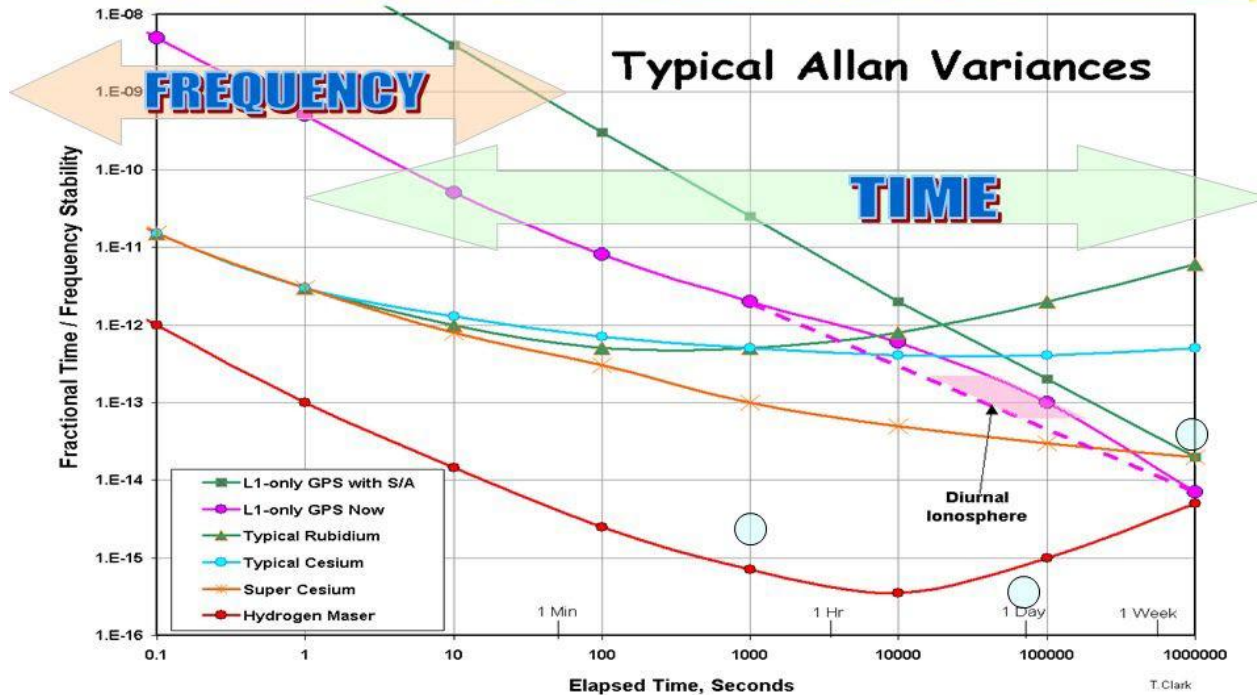

# VLBI Station

- VLBI Backend
  - VLBI Data Formatter
  - Data Recorder
  - Control Software

# VLBI Station

- VLBI Backend
  - DBBC2
  - Mark5B+ Recorder
  - Field System
  - Station Controller

# VLBI Station

- DBBC2
  - 2/4 RF/IF Input in a range up to 2.2 GHz
    - 1-512, 512-1024, 1024-1536, 1536-2048
    - 1-1024, 1024-2048
  - 2 VSI output connectors with 1 or 2 Gb/s each
  - 1024/2048 MHz sampling clock
  - Observing modes/firmware:
    - DDC (tunable, channel bandwidth between 1 MHz and 16 MHz, U&L, Continuous cal with 80 Hz synchronization, mode 'astro', 'geo', 'w-astro', 'test')
    - PFB (fixed tuning, channel bandwidth 32 MHz, all U or L depending on the Nyquist zone)
    - SPECTRA (optional with additional instrumentation)
  - <https://www.hat-lab.cloud/dbbc2/>



# VLBI Station

- Mark5B+ Recorder
  - 2 x SATA Disk Packs (8 x 4 TB each)
  - VSI Interface
  - Up to 2048 Mbps record / 1024 MHz playback
  - Linux Debian 3.2.68-1
  - Jiveab v 2.6.0
  - Streamstor sdk 9.2.1
  - <https://conduant.com/>

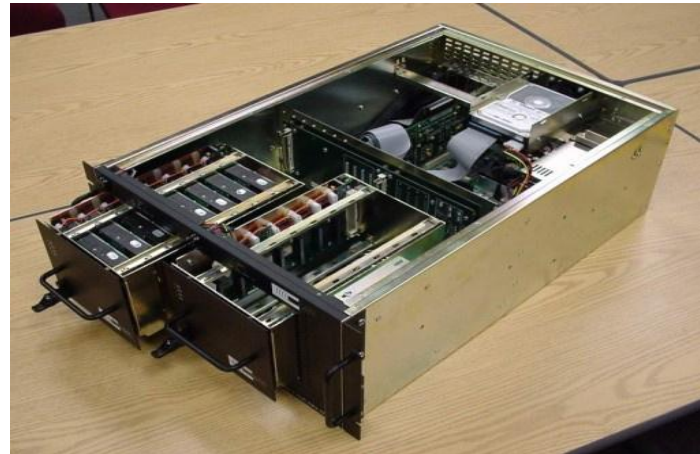



# VLBI Station

- Station Controller
  - Consists of multiple components working together to control and monitor the radio telescope.
  - Responsible for coordination of information, and also provides channels for control of radio telescope components either by the various sub-systems, physical operators or external interfaces

## Systems Engineering Approach

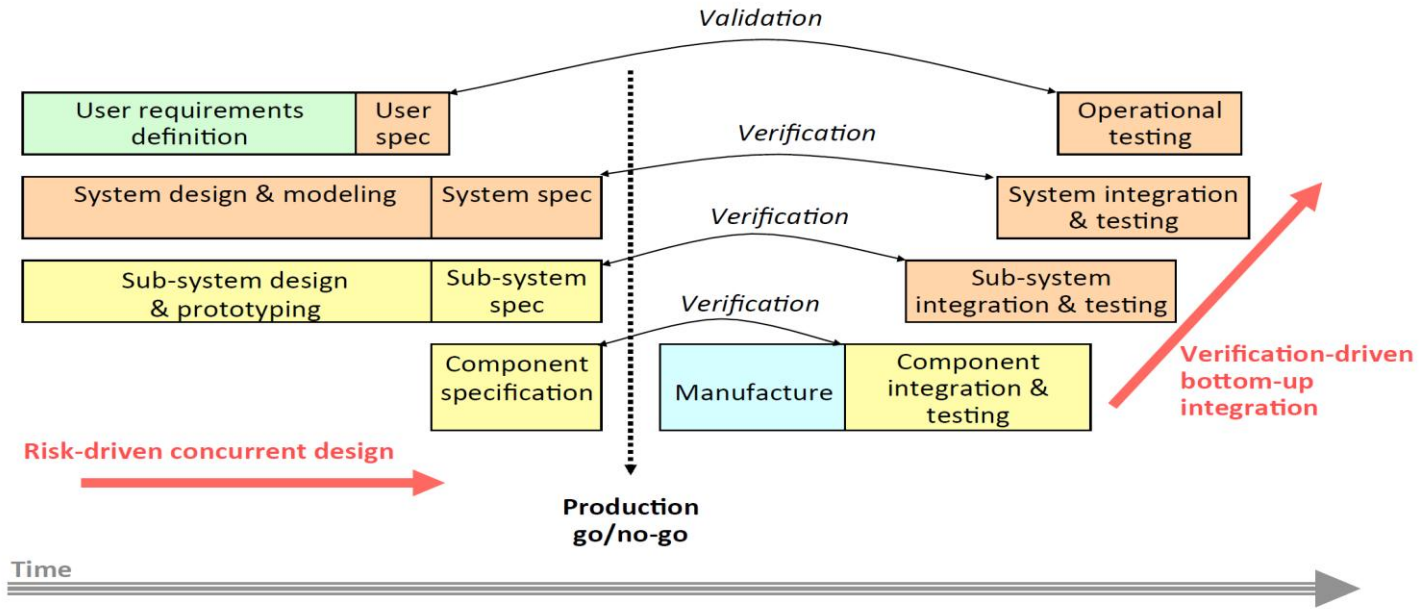

## Conversion Process

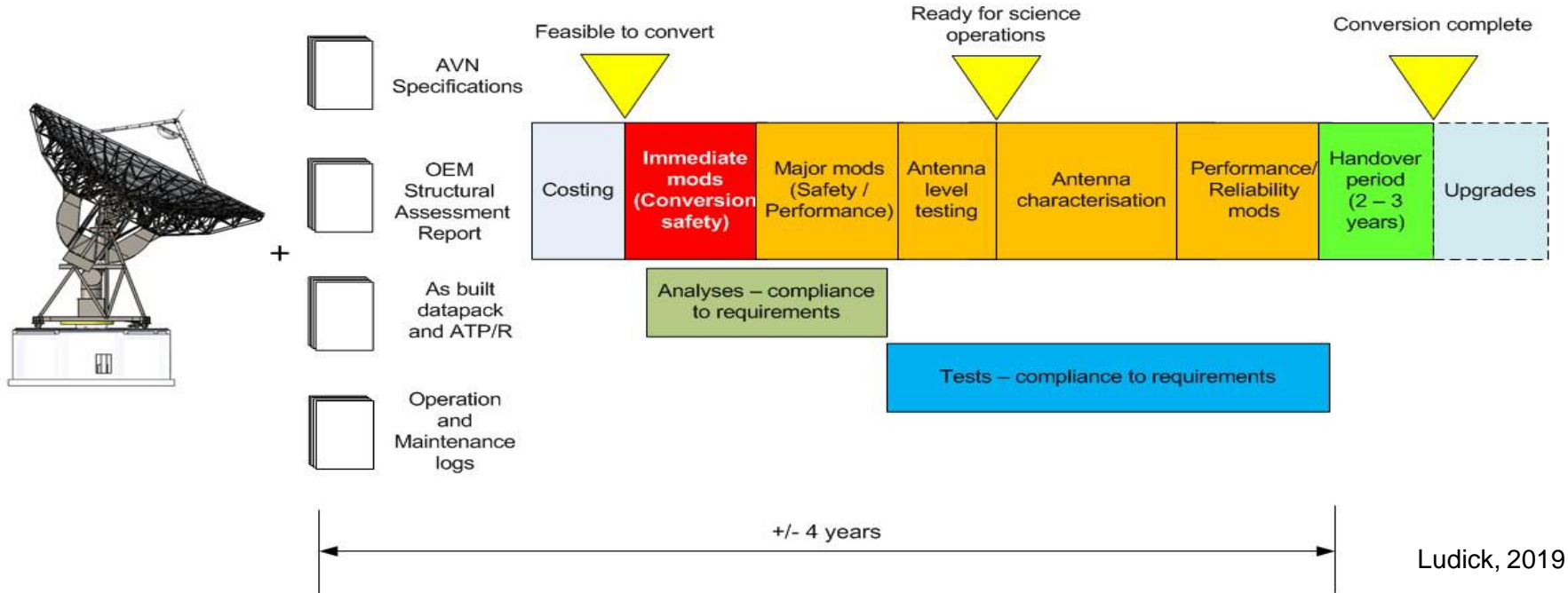

AVN



## Holistic approach - people



### Observatory Essential Skills

(hands-on 6 month training of 6 member team from partner country in SA and thereafter during conversion)

### Short courses not leading to degree / diploma

(eg Newton Fund, short courses (soldering, CAD, FEKO etc.))

**Training for the AVN and towards self-sufficiency in maintenance and operations of AVN stations and participation in SKA2**



### Tertiary qualification

(aimed at ensuring a robust user / research community, incl. scientists, engineers, technicians, etc.)

### Artisans - trades

(formal training towards a qualification as an artisans and other tradesmen etc.)

# Ghana

August 2019



# AVN and EVN

- Enhance the existing international VLBI network
  - Improve image fidelity of VLBI observations
  - Better uv sampling
  - Improve sensitivity

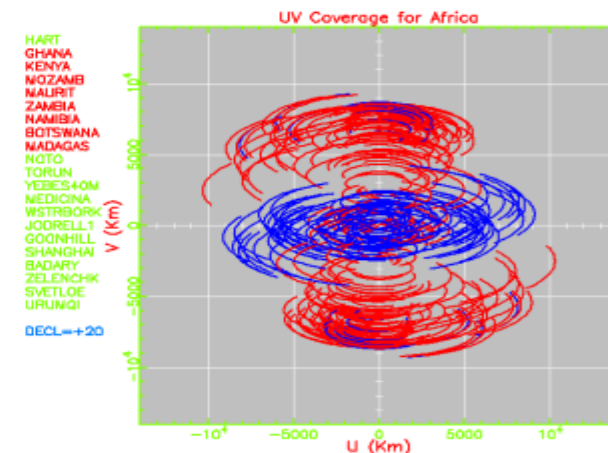
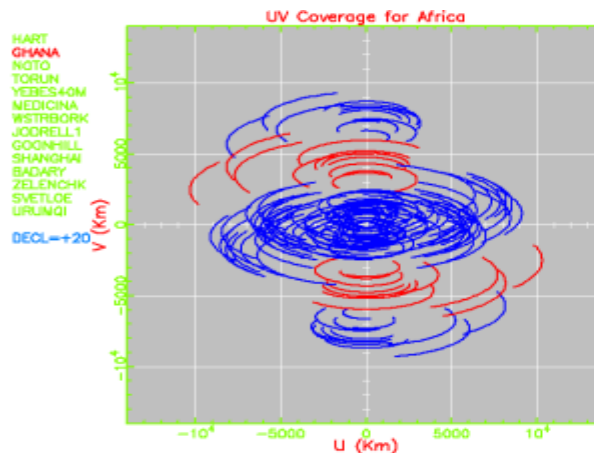
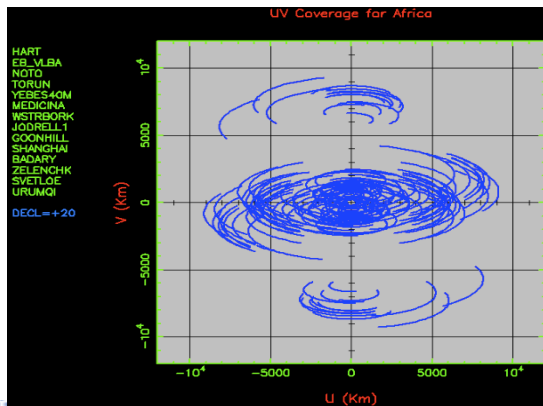

# AVN and Australian VLBI

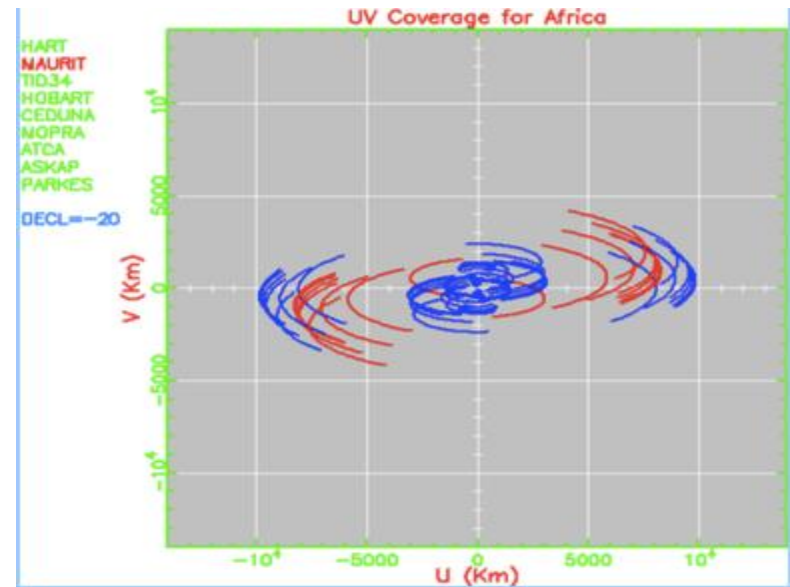
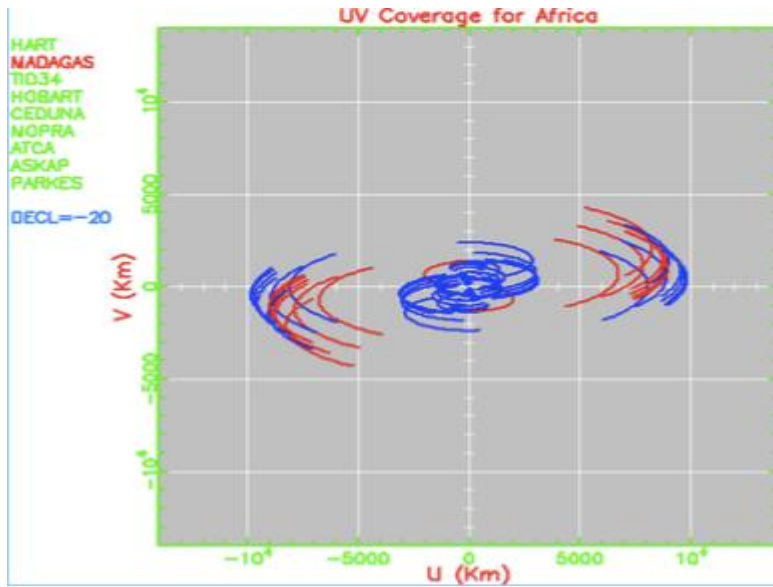

# MeerKAT-VLBI

- Increase VLBI sensitivity (baselines > 7000 km)
- Improve long baseline calibration
- Extend LBI coverage in the Southern hemisphere

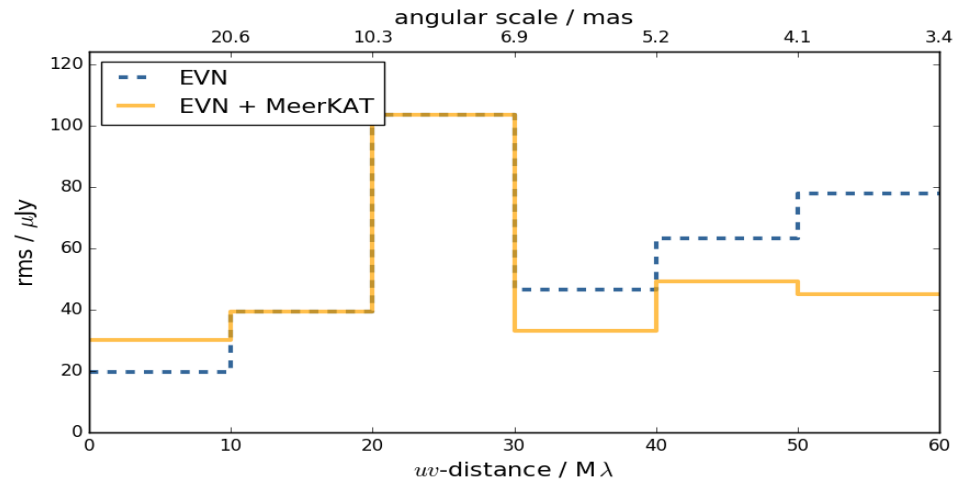

# MeerKAT-VLBI

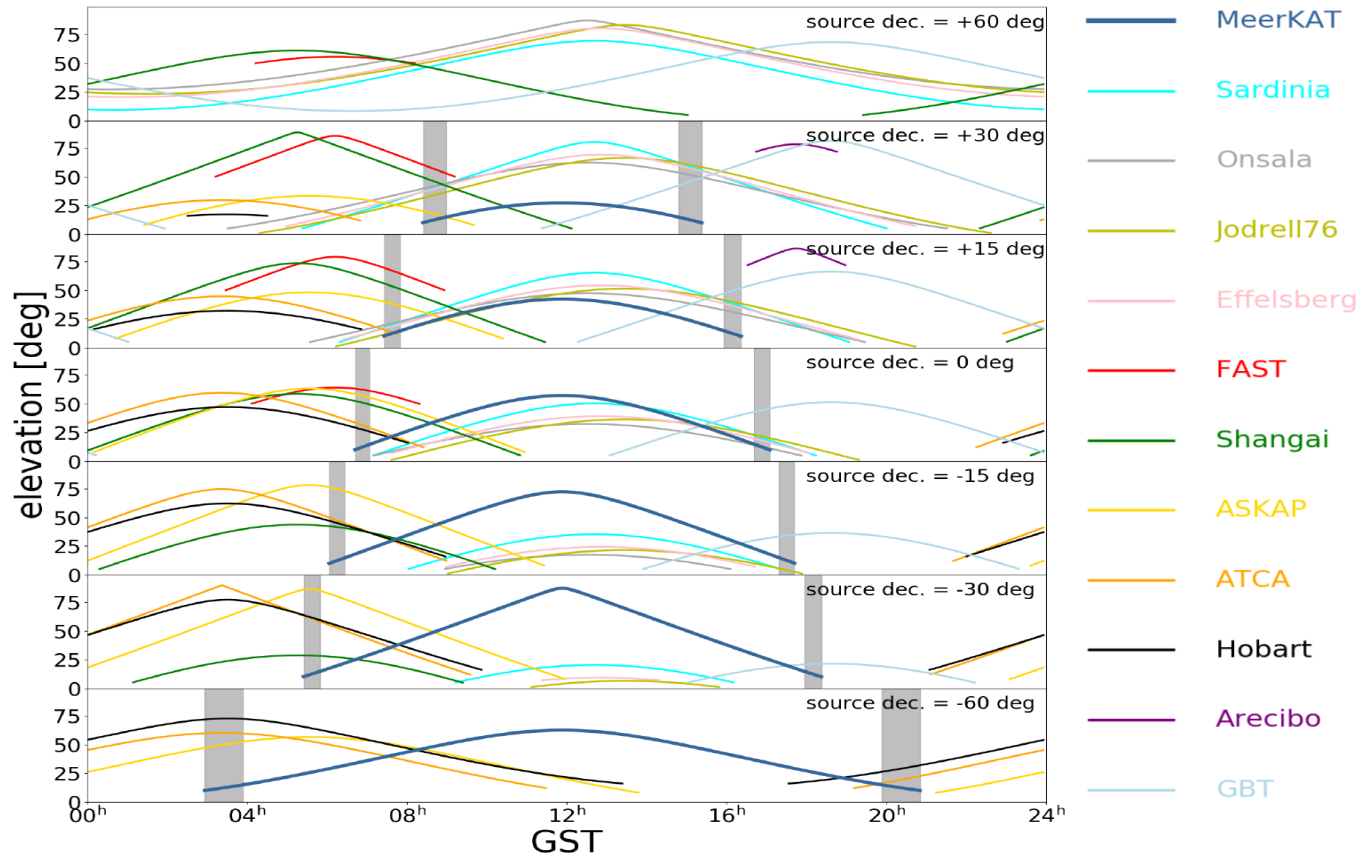

# Summary

- GRAO almost ready for VLBI
- Other stations to follow
- MeerKAT-VLBI
- SKA
- Human Capital for SKA



## Contact information

**Nkululeko Qwabe**  
Software Engineer and Data  
Scientist  
Email: [nqwabe@ska.ac.za](mailto:nqwabe@ska.ac.za)



[www.sarao.ac.za](http://www.sarao.ac.za)

The South African Radio Astronomy Observatory (SARAO) is a National Facility managed by the National Research Foundation and incorporates all national radio astronomy telescopes and programmes.