

# JEDI Projects: The Engineering behind Radio Telescopes

*A CHAT WITH*

**VenKAT**

**Project Manager, African VLBI Network**

**SKA-SA**

**[venkat@ska.ac.za](mailto:venkat@ska.ac.za)**

**0215067330/0797744725**

# What is JEDI?

- The Joint Exchange and Development Initiative (JEDI) is a concept to enhance development and education via a direct transfer of skills and expertise in any specific field.
- It is an initiative to provide development via joint exchange among stakeholders, by bringing them together in an informal but intense research environment to UNDERSTAND – half way to tackling and solving them!
- **Focus during this “Train the Trainer” workshop of JEDI is to share ideas on HOW YOU CAN STRUCTURE FOCUSSED JEDI PROGRAMMES OF ABOUT A WEEK EACH IN YOUR COUNTRY AS WE MOVE FORWARD TOWARDS THE BIGGEST RADIO TELESCOPE ARRAY, THE SQUARE KILOMETER ARRAY (SKA), IN THE CONTINENT.**
- ***Focus of my chat with you will be on the Engineering behind Radio telescopes***

# Plan of the Chat

- **What is a Radio Telescope?**
  - **Scientist's (*THE USER*) perspective**
  - **Engineer's (*The PROVIDER*) perspective**
- **Seed ideas for a JEDI on Spectrum Occupancy and RFI to a radio telescope**
- **Seed ideas for a series of JEDIs on different aspects of building a Radio Telescope array**

# What is a Radio Telescope – Scientist’s perspective

- Looks at the Universe with a “Radio Eye”
- The Scientist’s dream would be to get an “Ideal Radio Telescope Array” which will have INFINITE bandwidth and zero noise figure
  - Or at least with the best possible SENSITIVITY (*Bandwidth, Integration, Aperture size and Noise figure*)
  - And with the best possible RESOLUTION (*Interferometer – Connected element or Very Long Baseline (VLBI)*)
  - And over the WIDEST FREQUENCY RANGE (*facilitates “frequency hopping”, Doppler tracking*)
  - With the best POLARISATION characteristics.....
  - The best DYNAMIC performance (“Head Room”)
  - The best STABILITY with time against temperature and power variations
  - Lowest self-produced RFI
  - .....
- A Radio Telescope System processes and records the signals - very small perturbation in the background noise - as received from a celestial object in the field of view of the antenna
- The recorded signal with an accurate time stamp used for studies towards interpretation of the physics of the object and thus lead towards advancement of our knowledge in the fields of astronomy, astrophysics and cosmology through techniques of radiometry and spectroscopy.

# What is a Radio Telescope – Engineer’s perspective











- A Receiver system with an antenna which can **in a SAFE MANNER.....**
  - point to any desired location in the visible sky (steering control);
  - SLEWS between points in the sky at a fast rate (PID controller);
  - TRACKS an object (moves the antenna to compensate for the rotation of the earth) and keeps the object in the bore sight and records the “signals” as received in the field of view of the antenna
  - with the best possible noise figure (cryogenics), bandwidth (appropriate filtering) and dynamic range (linearity – 1 dB compression/ 3<sup>rd</sup> order intercept point)
  - With a stable performance against ambient temperature and utility power fluctuations over the integration period
- ***NO DIFFERENT FROM ANY OTHER COMMUNICATION RECEIVERS LIKE CELLPHONE, TELEVISION, SPACE LAUNCH AND TRACK SYSTEMS ETC!***

# The Bandwidth for Radio Astronomer

- International Telecommunication Union (ITU) has recognised Radio Astronomy as one of the ~30 services needing spectrum allocation.
- **The Electromagnetic spectrum is regulated internationally by the ITU**
- **The Electromagnetic spectrum is regulated nationally by the Independent Communications Authority of South Africa (ICASA) and similar bodies in each country.**
- Protected chunks of Spectrum from 9 kHz to 1 THz is available with a roughly octave spacing for continuum research in Radio Astronomy
- **Protected narrow chunks are also available for spectral line studies (Eg: 1610-1612.6 MHz for OH line research)**
- **Level of protection varies as PRIMARY (1400-1427 MHz), SECONDARY etc.**
- *However, the Radio Astronomy Receiver operates over a wider range of frequencies to study red-shifted lines and the designer needs to “harden” the design to achieve a linear system in the presence of other signals*
- *A major effort of coordination with other users, actively supported by the Spectrum Regulators of a country is CRITICAL for the success of endeavours in radio astronomy*
- *The actual RF band and the bandwidth chosen at a specific radio telescope station depends on the Science Goals of the telescope*

# The Bandwidth for Radio Astronomer

## RADIO SERVICES COLOR LEGEND

 AERONAUTICAL MOBILE	 INTER-SATELLITE	 RADIO ASTRONOMY
 AERONAUTICAL MOBILE SATELLITE	 LAND MOBILE	 RADIO DETERMINATION SATELLITE
 AERONAUTICAL RADIONAVIGATION	 LAND MOBILE SATELLITE	 RADIOLOCATION
 AMATEUR	 MARITIME MOBILE	 RADIOLOCATION SATELLITE
 AMATEUR SATELLITE	 MARITIME MOBILE SATELLITE	 RADIONAVIGATION
 BROADCASTING	 MARITIME RADIONAVIGATION	 RADIONAVIGATION SATELLITE
 BROADCASTING SATELLITE	 METEOROLOGICAL AIDS	 SPACE OPERATION
 EARTH EXPLORATION SATELLITE	 METEOROLOGICAL SATELLITE	 SPACE RESEARCH
 FIXED	 MOBILE	 STANDARD FREQUENCY AND TIME SIGNAL
 FIXED SATELLITE	 MOBILE SATELLITE	 STANDARD FREQUENCY AND TIME SIGNAL SATELLITE

<b>ACTIVITY CODE</b>	
 GOVERNMENT EXCLUSIVE	 GOVERNMENT/NON-GOVERNMENT SHARED
 NON-GOVERNMENT EXCLUSIVE	



[http://www.ntia.doc.gov/files/ntia/publications/spectrum\\_wall\\_chart\\_aug2011.pdf](http://www.ntia.doc.gov/files/ntia/publications/spectrum_wall_chart_aug2011.pdf)

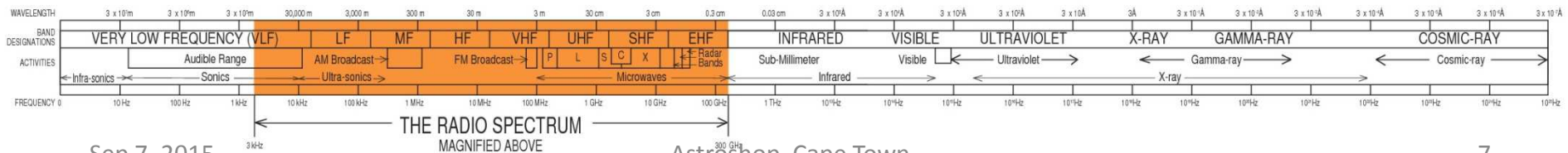

# Planning a JEDI Workshop for understanding RF Spectrum Occupancy and RFI to a Radio Telescope

- **Requirements:**
  - Yagi antenna (YA)
  - Log Periodic Dipole Antenna (LPDA)
  - 2 m tall mast x 2 (for YA and LPDA)
  - Magnetic Compass
  - External LNA and Power Supply (Optional)
  - Spectrum Analyser (SA) (Rohde and Schwarz FSH-8 (or equivalent )) with 2-port measurement and in-built LNA options
  - Interconnection cables
- ***ROM COST ESTIMATE: US \$30,000***

# Planning a JEDI Workshop for understanding RF Spectrum Occupancy and RFI to a Radio Telescope

- **Module 1 – Design of YA and LPDA**
- **Module 2 – Characterisation (or understand earlier measured data) of YA, LPDA, optional LNA and cable**
  - S-parameters
  - Beam pattern in the two polarisation for the antennas
- **Module 3 – Understand SA and write Data acquisition software from SA in the laptop**
- **Module 4 – Planning experimental set-up to measure RF Spectrum Occupancy at a location**
- **Module 5 – Conducting the data acquisition in both polarisation and around the horizon**
- **Module 6 – Data Analysis, interpretation and conclusion**
- **Module 7 – Discussion on mitigation strategies**

# Planning JEDIs on different aspects of building a Radio Telescope array

- **Engineering Disciplines involved in building a radio telescope array:**
  - RF/ Communication
  - Electromagnetics
  - Structural/ Mechanical
  - Electronics
  - Digital Signal Processing
  - Software
  - Civil
  - ....

# Planning JEDIs on Signal Chain aspect of building a Radio Telescope array

- **COMPONENTS OF THE RADIO TELESCOPE RECEIVER**
  - The Aperture Element (Dish)
  - The Electro-Magnetic to Electrical Converter (Feed and OMT)
  - The Low Noise Amplifier
  - The Local Oscillator
  - The Mixer
  - Gain, Band-Limit, filter and other RF functionalities
  - The Signal Transport Network (coaxial cable or optical fibre)
  - ADCs and The Back-end processor
  - The Data Storage and Archival
  - The Clock - Time and Frequency Reference
- **THE PURPOSE IS TO MAP THE BAND-LIMITED SIGNAL AS RECEIVED BY THE EM-E CONVERTER TO THE BACK END PROCESSOR IN POWER AS WELL AS FREQUENCY DOMAINS**

# A Signal Chain Block Diagram

**Ghana BM1 RF System block diagram**  
5 GHz and 6.7 GHz receiver line-ups  
dual circular polarisation

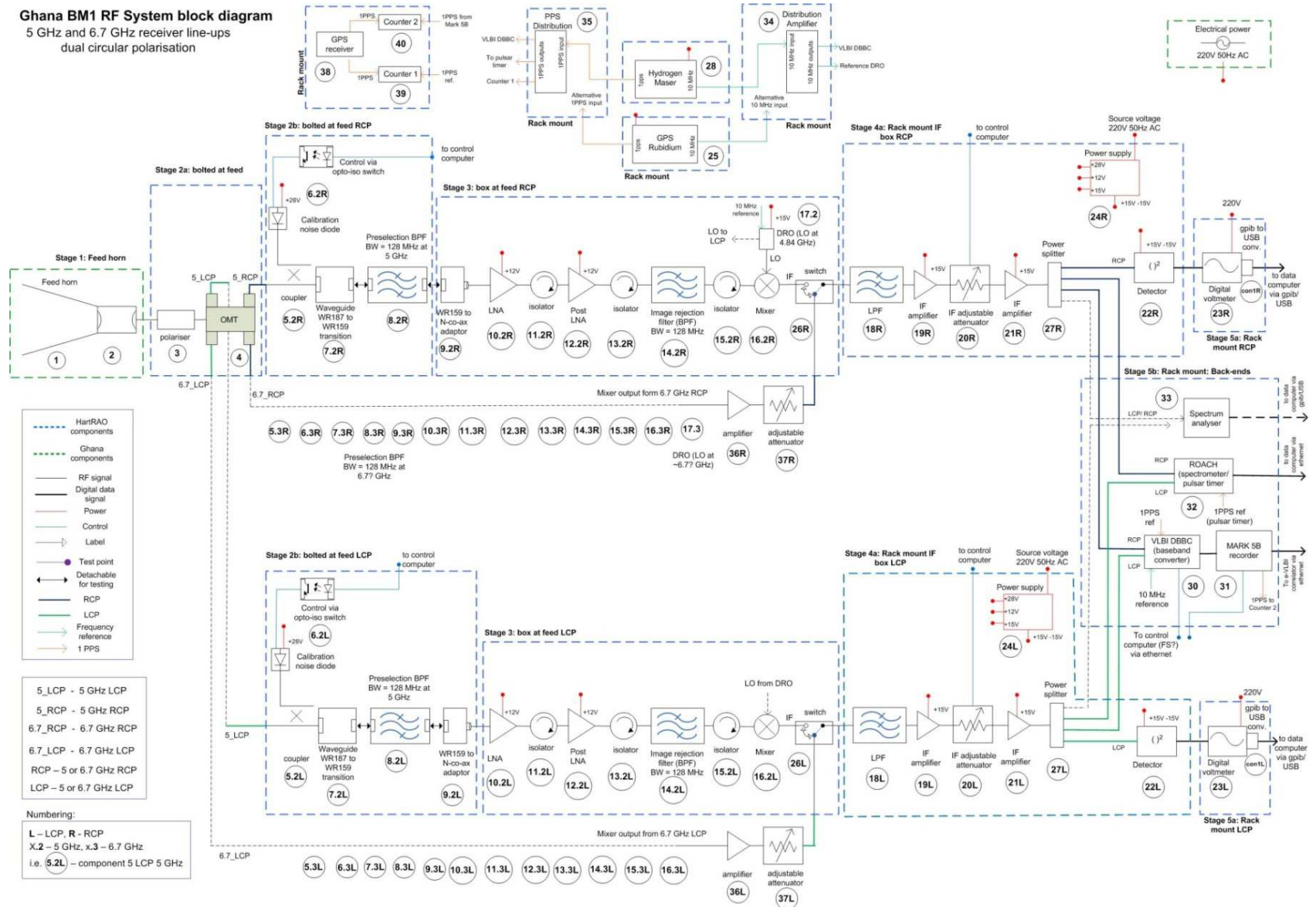

# Cascaded RFE Study for Receiver Temperature and Head-room

Notes: Parameters in RED are input parameters Parameters in BLACK are derived. Ver A Mar 15, 2k9 Ver B Apr 13, 2k9 Ver C Apr 28, 2k9 Ver D Jul 22, 2k9													
physical temp 77													
<b>BASIC SPECS AT EACH BLOCK:</b>													
	OMT OUT	Barrel	Dir Cptr	Cable	LNA	Stage 3	Stage 4	Stage 5	Stage 6	Stage 7	DBE		
1 dB compression point at input (dBm)	1000	1000	1000	1000	-38	.8	1000	-4	-10	0	-----	-----	-----
1 dB compression point at output (dBm)	1000	1000	1000	1000	1000	0	-----	1000	-----	-----	10	-----	-----
IP3 at input (dBm)	1000	1000	1000	1000	-----	2	1000	6	0	10	-----	-----	-----
IP3 at output (dBm)	1000	1000	1000	1000	1000	-----	-----	1000	-----	-----	-----	-----	-----
Noise Figure at input (dB)	0.026	0.052	0.033	0.15	9	6	15	16	19	-----	-----	-----	-----
Gain for RF Signal (dB)		-0.1	-0.2	-0.125	38	22	-6	-6	11.37	10	-----	-----	-----
<b>Cumulative Gain at a Point:</b>													
Cumulative RF Signal Gain (dB)	0	-0.1	-0.3	-0.425	37.575	59.575	53.575	48.575	59.945	-----	-----	-----	-----
<b>POWER AT EACH BLOCK OUTPUT (in dBm):</b>													
Nominal power in a 1.2-1.95 GHz bw (T = Row 50)	-96.945	-97.045	-97.245	-97.370	-59.370	-37.370	-43.370	-48.370	-37.000	-----	-----	-----	-----
<b>NOISE TEMPERATURE T (in K):</b>													
At a point in the receiver chain	1.763	3.507	2.201	10.191	2013.552	864.511	8880.605	11255.108	22745.519	-----	-----	-----	-----
Individual Block Contribution at input	1.763	3.589	2.359	11.239	0.352	0.001	0.039	0.156	0.023	-----	-----	-----	-----
Total Noise at Input (K)	19.521												
<b>Head room to 1 dB compression at INPUT of each block</b>													
	1096.945	1097.045	1097.245	59.370	51.370	1037.370	39.370	38.370	37.000	-----	-----	-----	-----
<div style="display: flex; justify-content: space-around;"> <div style="border: 1px solid black; padding: 5px; background-color: yellow;">LOSS MINIMISATION EFFORTS IN PROGRESS!</div> <div style="border: 1px solid black; padding: 5px; background-color: yellow;">STAGE 4 OTHER DETAILS: Flexstrand F5600 DB from Times Microwave used for above calculations</div> <div style="border: 1px solid black; padding: 5px; background-color: yellow;">STAGE 5 OTHER DETAILS: Nominal Attenuation Setting: 5 dB Gain adjustable from 0 to 63 dB in 0.5 dB steps</div> <div style="border: 1px solid black; padding: 5px; background-color: yellow;">STAGE 7 OTHER DETAILS: Nominal Attenuation Setting: 5 dB Gain adjustable from 0 to 15 dB in 1 dB steps</div> </div>													

# Planning a JEDI Workshop for understanding Radio Telescope Fundamentals

- **Requirements:**
  - A DsTV dish with LNB
  - A suitable two-axis mount for the dish
  - A rotation mechanism (stepper motor control)
  - Feedback of current position of the dish (potentiometer/encoder )
  - Provision of Safety features (limit switches)
  - A signal strength meter
  - Interconnection cables
  - DsTV decoder and a Television set
  - User Interface to control dish and record data in a laptop
- ***ROM COST ESTIMATE: US \$2,000***

# Planning a JEDI Workshop for understanding Radio Telescope Fundamentals

- **Module 1 – Understanding astronomical coordinate and Universal Time systems and the software algorithm for a source position on a given day and time**
- **Module 2 – Understanding PID controller (arduino microcontroller programming)**
- **Module 3 – Understanding Importance of Safety features**
- **Module 4 – Understanding the Signal Chain of the set-up and extrapolation to an operational radio telescope**
- **Module 5 – Understanding the mechanical aspects – stresses, deformation, torque, backlash etc**
- **Module 6 – Setting up the dish – levelling and true North considerations**
- **Module 7 – Simple experiments**
  - **Slew and point to different GSO satellites and see Free-to-Air TV programmes from different satellites**
  - **Slew across Sun and understand concepts of beamwidth, sun's temperature...**
  - **Track Sun and understand concepts of stability**
  - **Switch on a car or a tube light and understand concept of RFI....**

# Planning a JEDI Workshop for understanding Radio Telescope Fundamentals

- **Task for the Week**

- *What would you do to demonstrate concepts of an Interferometer and get fringes from Two DsTV receiver systems?*

***Thank FOR PATIENT  
LISTENING.....***

***Any Questions?***